

HiFi ENGINE®

For more Hi-Fi manuals and set-up information
please visit www.hifiengine.com

PARTS LIST

M-70 STEREO POWER AMPLIFIER

■ CONTENTS

EXPLODED VIEW (FRONT PANEL SIDE)	1
PARTS LIST	2
EXPLODED VIEW (REAR PANEL SIDE)	3
PARTS LIST	4
PARTS LIST (ELECTRONIC)	6 ~ 14

U : U.S.A. model

C : Canadian model

A : Australian model

R : General model

G : European model

B : British model

SINCE 1887



YAMAHA

NIPPON GAKKI CO., LTD. HAMAMATSU, JAPAN

EXPLODED VIEW(FRONT PANEL SIDE)

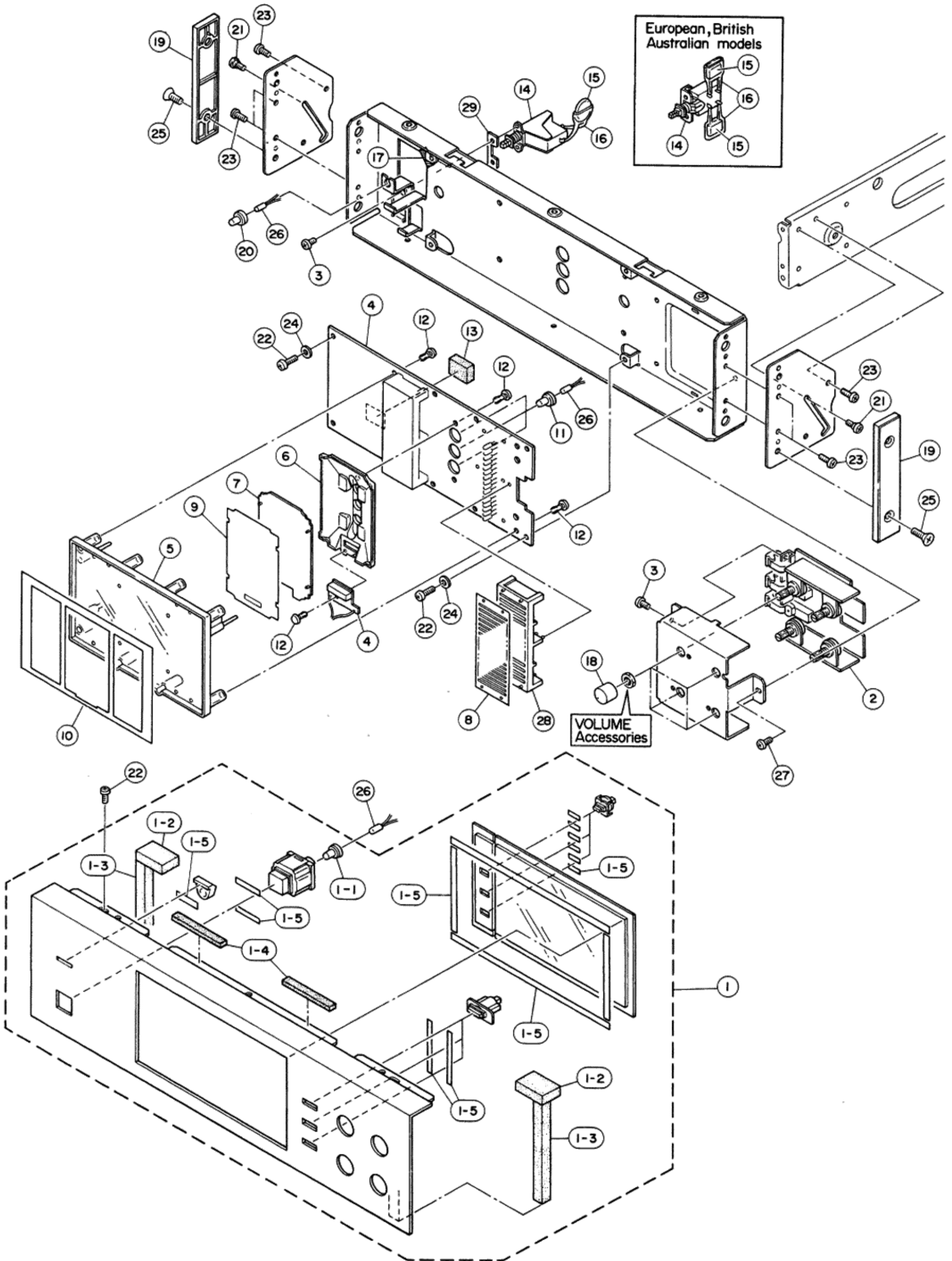

■ PARTS LIST

Ref. No.	Part No.	Description	部 品 名	Remarks	Common Model	Markets
※ 1	NB 60 20 60	Panel Unit	パネルユニット			J
※ "	NB 60 20 70	"	"			R,U,A,G,C,B
※ 1-1	CB 60 50 70	Cap, Lamp	ランプキャップ			
※ 1-2	CB 08 47 50	Damper	ダンパー			
※ 1-3	CB 60 50 50	Shade Tape	遮光テープ			
※ 1-4	CB 60 50 60	Damper	ダンパー			
※ 1-5	CB 07 41 90	Adhesive Tape	ダブルタックテープ			
※ 2	NA 07 44 90	PJ & VR Circuit Board	PJ & VRシート			J
※ "	NA 07 90 80	"	"			R,U,C
※ "	NA 07 96 60	"	"			A,G,B
※ 3	ED 33 00 60	Bind Head Screw	3x6 FCM3-Bℓ	バインド小ネジ		
※ 4	NA 07 75 00	Meter Circuit Board	メーターシート			J,R,A,G,B
※ "	NA 07 75 10	"	"			U,C
※ 5	CB 60 34 20	Meter Housing	メーターハウジング			
※ 6	CB 60 34 30	Reflector, Lamp	ランプリフレクター			
※ 7	CB 60 34 40	Diffusion Plate	拡散板			
※ 8	CB 60 34 50	Diffusion Sheet	拡散シート			
※ 9	CB 60 34 60	Scale Plate	メーター文字板			
※ 10	CB 60 34 70	Cover, Meter	メーターカバー			
※ 11	CB 60 44 10	Cap, Lamp	ランプキャップ			
※ 12	CB 06 88 80	Plastic Rivet	プラスチックリベット			
※ 13	CB 09 34 70	Spacer	スペーサー		A-550	
※ 14	KA 80 26 20	Push Switch	SDZ1P	プッシュスイッチ	Power	J
※ "	KA 80 25 50	"	SDZ1P-A	"	"	R,U,C
※ "	KA 80 21 70	"	SDS3P	"	"	A,G,B
※ 15	Fi 16 41 00	Ceramic Cap.	0.01μF 125V	セラコン		J
※ "	Fi 34 41 00	"	0.01μF	"		R,U,C
※ "	FR 16 41 00	Metalized Paper Cap.	0.01μF 250V	M P コ ン		A,G,B
※ 16	CB 07 21 90	Cover	コンデンサーカバー			"
※ "	CB 09 52 60	"	"			J,R,U,C
※ 17	CB 08 01 00	Adhesive Tape	粘着テープ			
※ 18	BA 08 15 50	Level Knob	レベルツマミ		M-50	
※ 19	CB 60 42 80	Side Plate	サイドプレート			
※ 20	CB 60 50 80	Cap, Lamp	ランプキャップ	PROTECTION		
※ 21	EN 93 70 10	Bind Head Tapping Screw	3x8 ZMC2-Bℓ	段付バインドタッピングネジ(2種)		A-960
※ 22	EN 33 00 10	Bind Head Tapping Screw	3x8 FCM3-Bℓ	バインドタッピングネジ(2種)		
※ 23	EN 34 00 10	Bind Head Bonding Tapping Screw	3x8 FCM3-Bℓ	バインドボンディング タッピングネジ(2種)		
※ 24	EV 20 33 00	Plain Washer	M3 FCM3-Bℓ	平座金		
※ 25	AA 60 82 20	Make Up Screw	ZMC2-Bℓ	化粧ネジ		
※ 26	JB 00 06 80	Lamp	14.5V 80mA	パイロットランプ		
※ 27	EN 33 00 20	Bind Head Tapping Screw	3x6 ZMC2-Bℓ	バインドタッピングネジ		
※ 28	CB 60 33 30	Reflector, LED	LED リフレクター			
※ 29	CB 60 29 20	Spacer, Switch	スイッチスペーサー			C
		Accessories Assembly	付 属 品 Ass'y			
※	Mi 08 17 90	Cord	1m	ピンコード		

※ New Parts (新規部品)

EXPLODED VIEW (REAR PANEL SIDE)

The diagrams ① and ② showing the transistors mounting are common between L and R channels. Refer the diagram about L channel.

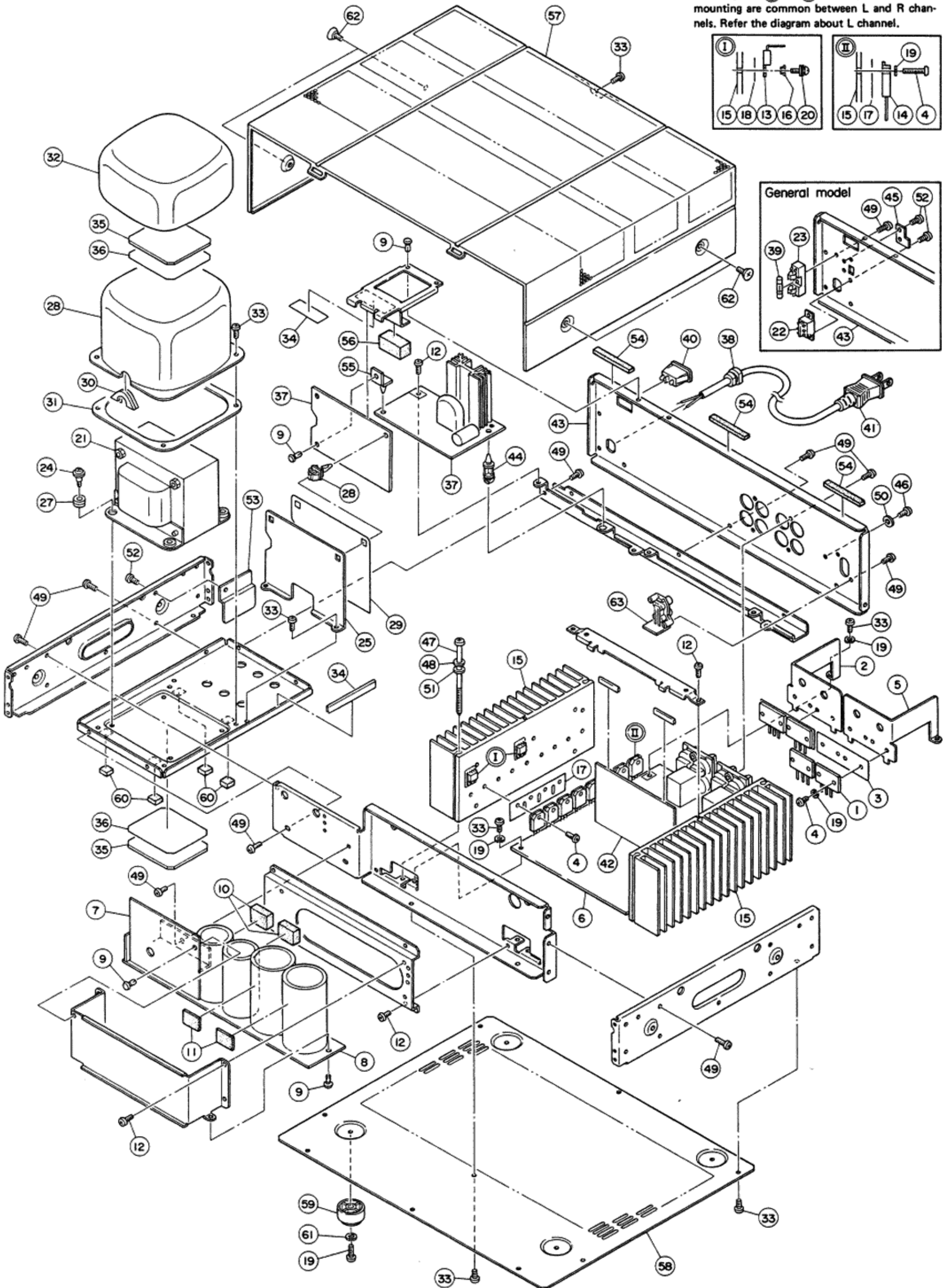

PARTS LIST

Ref. No.	Part No.	Description	部 品 名	Remarks	Common Model	Markets
1	iA 11:69:00	Transistor	2SA1169 (O,Y)	ト ラ ン ジ ス タ	TR155, 156	
"	iC 27:73:00	"	2SC2773 (O,Y)	"	TR157, 158	
2	BA 08:11:50	Heat Sink (L)		放 熱 板(L)		
3	iL 00:06:00	Mica Base		マ イ カ ベ ー ス		
4	ED 83:01:20	Bind Head Screw	3x12 FCM3-Bℓ	バ イ ン ド 小 ネ ジ		J
"	ED 33:01:20	"	3x12 ZMC2-Bℓ	"		R,U,A,G,C,B
5	BA 08:11:60	Heat Sink (R)		放 熱 板(R)		
6	NA 07:75:20	Main Circuit Board		メ イ ン シ ー ト		J
"	NA 07:75:30	"		"		R,A,G,B
"	NA 07:75:40	"		"		U,C
7	NA 07:76:00	Power Circuit Board		電 源 シ ー ト		J,R
"	NA 07:76:10	"		"		U,C
"	NA 07:76:20	"		"		A,G,B
8	NA 07:76:30	Electrolytic Cap Circuit Board		ケ ミ コ ン シ ー ト		J
"	NA 07:76:40	"		"		R,A,G,B
"	NA 07:76:50	"		"		U,C
9	CB 06:88:80	Plastic Rivet		プ ラ ス チ ッ ク リ ベ ッ ト		
10	CB 09:88:00	Spacer		ス ペ ー サ ー		T-7
11	CB 08:51:40	Antivibration Tape		防 振 テ ー プ		T-2
12	EN 33:00:20	Bind Head Tapping Screw	3x6 FCM3-Bℓ	バ イ ン ド タ ッ ピ ン グ ネ ジ (2種)		
13	iA 09:13:60	Transistor	2SA913A(P,Q,R,S)	ト ラ ン ジ ス タ	TR133, 134	
"	iC 19:13:60	"	2SC1913A(P,Q,R,S)	"	TR131, 132	
14	iA 11:46:00	"	2SA1146 (O,Y)	"	TR137,138,141,142 TR145,146,149,150	
"	iC 27:06:00	"	2SC2706 (O,Y)	"	TR135,136,139,140 TR143,144,147,148	
15	BA 08:11:30	Heat Sink		放 熱 板		
16	CB 07:28:80	Isolation Bush		絶 縁 ブ ッ シ ュ		
17	CB 60:43:10	Mica Base (4th)		4 連 マ イ カ		
18	iL 00:02:70	Mica Base		マ イ カ ベ ー ス		
19	EV 30:33:00	Spring Washer	M3 FCM3-Bℓ	ス プ リ ン グ ワ ッ シ ャ ー		
20	EH 02:60:80	Cums Head Screw SP Washer	M2.6x8 ZMC2-Y	セ ム ス ナ ベ 小 ネ ジ (ダ ブ ル セ ム ス)	(Sems Type)	R,U,A,G,C,B
"	ED 32:61:00	Bind Head Screw	M2.6x10 FCM3-Bℓ	バ イ ン ド 小 ネ ジ		J
"	EV 30:32:60	Spring Washer	M2.6 FCM3-Bℓ	ス プ リ ン グ ワ ッ シ ャ ー		"
21	GA 64:74:00	Power Transformer		電 源 ト ラ ン ス		"
"	GA 64:75:00	"		"		U
"	GA 64:76:00	"		"		C
"	GA 64:77:00	"		"		G
"	GA 64:79:00	"		"		A,B
"	GA 64:78:00	"		"		R
22	KA 40:07:40	Slide Switch		ス ラ イ ド ス イ ッ チ		"
23	LB 20:13:00	Fuse Holder		ヒ ュ ー ズ ホ ル ダ ー		"
24	AA 60:38:50	Tight Screw		段 付 ネ ジ		A-760
25	AA 60:75:70	CS Holder		CS ホ ル ダ ー		
26	BA 08:10:90	Cover, Transformer		ト ラ ン ス カ バ ー		
27	CB 09:99:10	Rubber, Antivibration		防 振 ゴ ム		A-760
28	CB 09:98:30	P.C.B. Support		P.C.B. サ ポ ー ト		A-760
29	CB 60:42:70	Isolation Plate		絶 縁 板		
30	CB 60:50:90	Bush		リ ー ド ブ ッ シ ュ		
31	CB 60:51:00	Cover, Packing		カ バ ー、バ ッ キ ン グ		
32	CB 60:41:00	"		"		A-1060
"	CB 60:58:30	"		"		U,C
33	EN 33:00:10	Bind Head Tapping Screw	3x8 FCM3-Bℓ	バ イ ン ド タ ッ ピ ン グ ネ ジ		
34	CB 08:01:00	Tape		粘 着 テ ー プ		
35	AA 60:96:20	Plate		プ レ ー ト		A-1060

* New Parts (新規部品)

Ref. No.	Part No.	Description		部 品 名	Remarks	Common Model	Markets		
36	CB 60 71 90	Damper Tape		ダンパーテープ		A-1060			
37	NA 07 77 00	Control Circuit Board		制御シート			J		
"	NA 07 77 10	"		"			R		
"	NA 07 77 20	"		"			U,C		
"	NA 07 77 30	"		"			A,G,B		
38	CB 80 68 50	Cord Stopper		コードストッパー			J		
"	CB 07 27 50	"		"			R,U,A,G,C,B		
39	KB 00 13 00	Fuse	T7.0A 250V	ヒューズ			R		
40	LB 20 18 10	AC Out Let (Single)		AC アウトレット			J,R,U		
"	LB 20 20 70	"		"			C		
41	MG 00 12 20	Power Cord	15A 125V 2m	電源コード			J		
"	MG 00 07 80	"	6A 250V 2m	"			R		
"	MG 00 13 60	"	13A 125V 2m	"			U,C		
"	MG 00 09 10	"	6A 250V 2m	"			G		
"	MG 00 09 20	"	7.5A 250V 2.5m	"			A		
"	MG 00 10 00	"	6A 300/500V 2m	"			B		
42	NA 07 78 40	Pre Drive Circuit Board		プリドライブシート			J		
"	NA 07 78 50	"		"			R,A,G,B		
"	NA 07 78 60	"		"			U,C		
43	AA 60 76 30	Rear Panel		リアパネル			J		
"	AA 60 76 40	"		"			R		
"	AA 60 76 50	"		"			U,C		
"	AA 60 76 60	"		"			G		
"	AA 60 76 70	"		"			A,B		
44	CB 09 26 80	P.C.B. Support		P.C.B.サポート					
45	CB 60 14 40	Switch Guard		VS ストッパー			R		
46	EZ 00 14 00	Ground Terminal Screw	3x13.5 MFMi-II	アース端子ネジ					
47	EG 34 09 70	Pan Head Screw	M4x97 FCM3-Bℓ	ナベ小ネジ					
48	EV 20 34 00	Plain Washer	M4 FCM3-Bℓ	平座金					
49	EN 30 00 10	Bind Bonding Head Tapping Screw	3x8 FCM3-Bℓ	バインドボンディング タッピングネジ(2種)					
50	EV 90 13 60	Sems Plain Washer	φ3.6xφ10xt0.8 FNM3-3g	セムス平座金		B-6			
51	EV 20 84 00	Plain Washer	φ4 FCM3-Bℓ	平座金			J		
52	ED 33 00 60	Bind Head Screw	3x6 FCM3-Bℓ	バインド小ネジ			R,A,G,B		
53	AA 60 97 40	Protection Plate		保護金具			A,G,B		
54	CB 09 04 40	Rubber, Antivibration		防振ゴム					
55	CB 09 12 90	P.C. Board Holder		基板ホルダー		T-550			
56	CB 60 74 30	Cushion, Antivibration		防振クッション					
57	AA 60 75 10	Top Cover		トップカバー					
58	AA 60 75 30	Botton Cover		ボトムカバー					
59	CB 07 94 90	Leg		脚					
60	CB 60 73 40	Rubber, Antivibration		防振ゴム					
61	EN 33 01 00	Bind Head Tapping Screw	3x16 ZMC2-Bℓ	バインドタッピングネジ(2種)					
62	AA 60 82 10	Cabinet Fixed Screw	ZMC2-Bℓ	化粧ネジ					
63	NA 07 44 90	PJ & VR Circuit Board		PJ & VRシート			J		
"	NA 07 90 80	"		"			R,U,C		
"	NA 07 96 60	"		"			A,G,B		
	CB 06 92 50	Binding Tie		インシュロックタイ					

✦ New Parts (新規部品)

■PARTS LIST(ELECTRONIC)

Ref. No.	Part No.	Description	部 品 名	Remarks	Common Model	Markets		
※	NA 07:44:90	PJ & VR Circuit Board		P J & V R シ ー ト		J		
※	NA 07:90:80	"		"		R,U,C		
※	NA 07:96:60	"		"		A,G,B		
※	C401,402	FT 55:23:90 Polypropylene Film Cap.	390pF 50V	ポリプロピレンフィルムコン				
	R401,402	HJ 35:53:90 Carbon Resistor	390Ω RD25	カ ー ボ ン 抵 抗				
※	VR401 ~ VR404	HS 00:04:00 Variable Resistor	B50kΩ	可 変 抵 抗 器				
※	SW401	KA 90:22:20 Push Switch		カム付プッシュスイッチ				
※	PJ401	LB 20:19:80 Pin Jack	2P (L Type)	2P ピンジャックL型 エッジ付(金メッキ)				
※	NA 07:75:00	Meter Circuit Board		メ ー タ ー シ ー ト		J,R,A,G,B		
※	NA 07:75:10	"		"		U,C		
※	C501,502	UW 96:62:20 Electrolytic Cap.	2.2μF 50V	ケ ミ コ ン				
	C503	UW 96:54:70 "	0.47μF 50V	"				
※	C504,505	UA 25:41:50 Mylar Cap.	0.015μF 50V	マ イ ラ ー コ ン				
※	C506	UW 96:61:00 Electrolytic Cap.	1μF 50V	ケ ミ コ ン				
	C507	FG 44:41:00 Ceramic Cap.	0.01μF 50V	セ ラ コ ン				
	C509,510	UA 75:61:00 Mylar Cap.	1μF 63V	マ イ ラ ー コ ン				
	C511,512	UW 83:73:30 Electrolytic Cap.	33μF 16V	ケ ミ コ ン				
※	C513	UW 96:61:00 "	1μF 50V	"				
	C515,516	FA 45:31:80 Mylar Cap.	0.0018μF 50V	マ イ ラ ー コ ン				
	R501,502	HJ 35:81:00 Carbon Resistor	100kΩ RD25	カ ー ボ ン 抵 抗				
	R503,504	HJ 35:81:50 "	150kΩ "	"				
	R505,506	HJ 35:71:20 "	12kΩ "	"				
	R507	HL 51:61:50 Metal Oxide Film Resistor	1.5kΩ 1P	酸 金 抵 抗				
	R509,510	HJ 35:61:20 Carbon Resistor	1.2kΩ RD25	カ ー ボ ン 抵 抗				
	R511,512	HJ 35:71:00 "	10kΩ "	"				
	R513	HJ 35:62:70 "	2.7kΩ "	"				
	R515,516	HJ 35:51:00 "	100Ω "	"				
	R517~538	HJ 35:61:00 "	1kΩ "	"				
	R539,540	HJ 35:71:00 "	10kΩ "	"				
	R541,542	HJ 35:51:00 "	100Ω "	"				
	R543~563	HJ 35:61:00 "	1kΩ "	"				
	R565,566	HJ 35:71:00 "	10kΩ "	"				
	R567	HJ 35:65:60 "	5.6kΩ "	"				
	R568	HJ 35:71:50 "	15kΩ "	"				
	R569	HJ 35:61:50 "	1.5kΩ "	"				
	R570	HJ 35:56:80 "	680Ω "	"				
	R571,572	HJ 35:66:80 "	6.8kΩ "	"				
	R573,574	HJ 35:64:70 "	4.7kΩ "	"				
	R575,576	HJ 35:63:90 "	3.9kΩ "	"				
	R577,578	HJ 35:61:00 "	1kΩ "	"				
	R579	HJ 35:83:90 "	390kΩ "	"				
	R581,582	HJ 35:71:20 "	12kΩ "	"				
	R583,584	HJ 35:58:20 "	820Ω "	"				
	R585,586	HJ 35:62:70 "	2.7kΩ "	"				
	R587,588	HJ 35:64:70 "	4.7kΩ "	"				
	R589,590	HJ 35:81:80 "	180kΩ "	"				
	R591	HJ 35:82:70 "	270kΩ "	"				
	R592,593	HJ 35:75:60 "	56kΩ "	"				
	R594	HJ 35:51:00 "	100Ω "	"				
	R595	HJ 35:75:60 "	56kΩ "	"				
	VR501,502	HT 37:00:10 Semi Variable Resistor	B1kΩ	半 固 定 抵 抗	Inter-changeable			
	"	HT 77:00:30 "	B1kΩ	"				

※ New Parts (新規部品)

Ref. No.	Part No.	Description	部 品 名	Remarks	Common Model	Markets
TR501	iC 18:15:00	Transistor	2SC1815	ト ラ ン ジ ス タ		
TR502	iA 10:15:10	"	2SA1015	"		
TR503,504	iE 10:05:00	FET	2SK68A	F E T		
※ TR505,506	iE 10:05:10	"	" (K1, K2)	"	Inter-changeable	
"	iE 10:05:20	"	" (L1, L2)	"		
TR507,508	iE 10:05:00	"	"	"		
D501	iF 00:14:70	Zener Diode	RD6.2EB2	ツェナーダイオード		
D502	iF 00:03:50	"	WZ130	"		
※ D503 ~ D542	iF 00:32:20	LED	SLR-34DW	L E D		
D543	iF 00:23:10	"	LD-701	"		
D544,545	iF 00:00:40	Diode	1S1555	ダ イ オ ー ド		
D546	iH 00:07:20	"	W03B	"		
IC501	iG 03:07:00	IC	TA7318P	I C		
IC502	iG 00:13:90	"	NJM4558DV	"		
IC503 ~ IC506	iG 03:06:00	"	TA7612AP	"		
※ SW501	KA 90:22:10	Push Switch with Cam		カム付プッシュスイッチ(3連単動)		
	LA 00:21:10	Wrapping Terminal	P = 5 2P (i Type)	i型ラッピング端子板		
	LA 00:21:20	"	P = 5 3P (")	"		
	LA 00:20:30	"	P = 5 4P (")	"		
※	CB 60:33:30	LED Reflector		L E D リ フ レ ク タ ー		
※	NA 07:75:20	Main Circuit Board		メ イ ン シ ー ト		J
※	NA 07:75:30	"		"		R,A,G,B
※	NA 07:75:40	"		"		U,C
C101,102	UA 25:41:00	Mylar Cap.	0.01 μ F 50V	マ イ ラ ー コ ン		
C103,104	FT 55:23:90	Polypropylene Film Cap.	390pF 50V	ポリプロピレンフィルムコン		J
"	FG 41:23:90	"	390pF 50V	"		R,U,A,G,C,B
※ C105~108	UW 91:81:00	Electrolytic Cap.	100 μ F 6.3V	ケ ミ コ ン		
※ C109~112	UW 94:71:00	"	10 μ F 25V	"		
C115~118	FV 69:72:20	"	22 μ F 100V	プラスチックケミコン		J
"	UW 69:72:20	"	22 μ F 100V	ケ ミ コ ン		R,U,A,G,C,B
C119~122	FG 41:22:20	Ceramic Cap.	220pF 50V	セ ラ コ ン		
※ C123,124	FC 02:41:00	Mylar Cap.	0.01 μ F 100V	マ イ ラ ー コ ン		
C125~128	FG 41:21:00	Ceramic Cap.	100pF 50V	セ ラ コ ン		
C129~132	UW 86:72:20	Electrolytic Cap.	22 μ F 50V	ケ ミ コ ン		
※ C133~136	UA 25:42:20	Mylar Cap.	0.022 μ F 50V	マ イ ラ ー コ ン		
C137~140	FT 55:21:00	Polypropylene Film Cap.	100pF 50V	ポリプロピレンフィルムコン		
C141~144	UA 25:51:00	Mylar Cap.	0.1 μ F 50V	マ イ ラ ー コ ン		
※ C145~148	UA 25:42:20	"	0.022 μ F 50V	"		
C149,150	UA 25:44:70	"	0.047 μ F 50V	"		
C151	FM 50:73:30	Electrolytic Cap.	33 μ F 16V	Z コ ン		
C152	UW 91:81:00	"	100 μ F 6.3V	ケ ミ コ ン		
※ C153	UA 25:42:20	Mylar Cap.	0.022 μ F 50V	マ イ ラ ー コ ン		
※ C155~158	UA 25:42:20	"	0.022 μ F 50V	"		
C159,160	FC 25:51:00	Metallized Mylar Cap.	0.1 μ F 250V	M M コ ン		
※ C161,162	FC 02:41:00	Mylar Cap.	0.01 μ F 100V	マ イ ラ ー コ ン		
L101,102	GD 90:03:70	Coil	1.5 μ H	空 芯 コ イ ル		
R101,102	HV 35:46:80	Flame Proof Carbon Resistor	68 Ω RDF25SF	不燃化カーボン抵抗		
R103~106	HV 35:44:70	"	47 Ω "	"		
R107~110	HV 35:54:70	"	470 Ω "	"		
R111~118	HV 35:58:20	"	820 Ω "	"		
R119~126	HJ 35:48:20	Carbon Resistor	82 Ω RD25	カ ー ボ ン 抵 抗		
R127~130	HV 35:54:70	Flame Proof Carbon Resistor	470 Ω RDF25SF	不燃化カーボン抵抗		

※ New Parts (新規部品)

Ref. No.	Part No.	Description	部 品 名	Remarks	Common Model	Markets		
R131~134	HJ 35 62 20	Carbon Resistor	2.2kΩ RD25	カーボン抵抗				
R135~142	HJ 35 73 90	"	39kΩ "	"				
R143~146	HJ 35 63 30	"	3.3kΩ "	"				
R147,148	HJ 35 68 20	"	8.2kΩ "	"				
R149,150	HJ 35 64 70	"	4.7kΩ "	"				
R151,152	HJ 35 62 20	"	2.2kΩ "	"				
R153~156	HJ 35 62 70	"	2.7kΩ "	"				
R157~160	HJ 35 76 80	"	68kΩ "	"				
R161~164	HJ 35 71 00	"	10kΩ "	"				
R165~168	HV 35 51 50	Flame Proof Carbon Resistor	150Ω RDF25SF	不燃化カーボン抵抗				
R169~172	HV 35 61 20	"	1.2kΩ "	"				
* R173,174	HV 35 63 90	"	3.9kΩ "	"				
R175~178	HV 35 42 20	"	22Ω "	"				
R179~182	HV 35 45 60	"	56Ω "	"				
R183~194	HV 35 34 70	"	4.7Ω "	"				
R195,196	HV 35 48 20	"	82Ω "	"				
R197~200	HZ 00 21 70	Metal Plate Resistor	0.68Ω 3P RGC-3	金属板抵抗				
R201~212	HZ 00 21 60	"	0.33Ω 3P "	"				
R213~216	HV 35 34 70	Flame Proof Carbon Resistor	4.7Ω RDF25SF	不燃化カーボン抵抗				
R217~220	HU 57 72 70	Metal Film Resistor	27kΩ SN14K2E(F)	金属被膜抵抗				
R221~224	HJ 35 71 00	Carbon Resistor	10kΩ RD25	カーボン抵抗				
R225~228	HJ 35 73 90	"	39kΩ "	"				
R229~232	HJ 35 71 00	"	10kΩ "	"				
R233~236	HJ 35 48 20	"	82Ω "	"				
R237~240	HU 57 66 80	Metal Film Resistor	6.8kΩ SN14K2E(F)	金属被膜抵抗				
R241~244	HU 57 63 30	"	3.3kΩ "	"				
R245~248	HJ 35 71 00	Carbon Resistor	10kΩ RD25	カーボン抵抗				
R249~252	HJ 35 51 00	"	100Ω "	"				
R253~256	HJ 35 62 20	"	2.2kΩ "	"				
R257~264	HJ 35 72 20	"	22kΩ "	"				
R265~268	HJ 35 73 90	"	39kΩ "	"				
* R269,270	HZ 00 22 60	Metal Plate Resistor	0.1Ω 5P RGC-5	金属板抵抗				
R271,272	HZ 00 21 50	Cement Molded Resistor	10Ω 5P	セメント抵抗				
R273,274	HJ 35 34 70	Carbon Resistor	4.7Ω RD25	カーボン抵抗				
R275	HJ 35 72 20	"	22kΩ "	"				
R276	HJ 35 71 00	"	10kΩ "	"				
R277	HJ 35 73 90	"	39kΩ "	"				
R278	HJ 35 63 90	"	3.9kΩ "	"				
R279	HJ 35 81 50	"	150kΩ "	"				
R280,281	HJ 35 78 20	"	82kΩ "	"				
* R282	HL 71 53 30	Metal Oxide Film Resistor	330Ω 1P	酸金抵抗				
R283	HJ 35 41 00	Carbon Resistor	10Ω RD25	カーボン抵抗				
R285	HJ 35 76 80	"	68kΩ "	"				
R286	HJ 35 71 20	"	12kΩ "	"				
R287	HJ 35 74 70	"	47kΩ "	"				
R288	HJ 35 71 20	"	12kΩ "	"				
R289,290	HJ 35 41 00	"	10Ω "	"				
R291~294	HU 57 71 80	Metal Film Resistor	18kΩ SN14K2E(F)	金属被膜抵抗				
R295,296	HJ 35 81 00	Carbon Resistor	100kΩ RD25	カーボン抵抗				
R297~312	HJ 35 73 90	"	39kΩ "	"				
R313,314	HV 35 41 00	Flame Proof Carbon Resistor	10Ω RDF25SF	不燃化カーボン抵抗				
R315,316	HL 81 41 00	Metal Oxide Film Resistor	10Ω 1P	酸金抵抗				
R317,318	HJ 35 52 20	Carbon Resistor	220Ω RD25	カーボン抵抗				

* New Parts (新規部品)

Ref. No.	Part No.	Description	部 品 名	Remarks	Common Model	Markets
R319,320	HJ 35:51:00	Carbon Resistor	100Ω RD25	カーボン抵抗		
R321,322	HJ 35:61:00	"	1kΩ "	"		
R323~326	HJ 35:78:20	"	82kΩ "	"		
※ VR101 VR104	HY 00:09:90	Metal Grazed Variable Resistor	B500Ω	メタルグレースボリューム		
TR101 TR102	iC 27:05:00	Transistor	2SC2705(O,Y)	トランジスタ		
TR103 TR104	iA 11:45:00	"	2SA1145(O,Y)	"		
TR105~ TR108	iA 10:15:70	"	2SA1015(O,Y)	"		
TR109~ TR116	iC 18:15:70	"	2SC1815(O,Y)	"		
TR117~ TR120	iA 10:15:70	"	2SA1015(O,Y)	"		
TR121 TR122	iC 22:40:00	"	2SC2240(GR,BL)	"		
TR123 TR124	iC 15:09:30	"	2SC1509(Q,R)	"		
TR125 TR126	iA 07:77:30	"	2SA777(Q,R)	"		
TR127 TR128	iC 27:05:00	"	2SC2705(O,Y)	"		
TR129 TR130	iA 11:45:00	"	2SA1145(O,Y)	"		
TR151 TR152	iC 18:15:00	"	2SC1815	"		
TR153 TR154	iA 10:15:70	"	2SA1015(O,Y)	"		
TR159 TR160	iB 06:49:00	"	2SB649(C,D)	"		
TR161 TR162	iD 06:69:00	"	2SD669(C,D)	"		
TR163 TR164	iA 10:15:70	"	2SA1015(O,Y)	"		
TR165 TR166	iC 18:15:00	"	2SC1815	"		
TR167 TR168	iC 22:40:00	"	2SC2240(GR,BL)	"		
TR169 TR170	iA 09:70:00	"	2SA970(GR,BL)	"		
TR171	iA 06:73:10	"	2SA673(C,D)	"		
TR172	iA 07:77:30	"	2SA777(Q,R)	"		
TR173	iC 18:15:00	"	2SC1815	"		
TR174	iA 10:15:70	"	2SA1015(O,Y)	"		
TR175 TR176	iC 18:15:00	"	2SC1815	"		
D101,102	iF 00:07:90	Varistor	MV12	バリスタ		
D103,104	iF 00:14:70	Zener Diode	RD6.2EB2	ツェナーダイオード		
D105~112	iF 00:14:00	Diode	1SS82	ダイオード		
D113~116	iF 00:00:40	"	1S1555	"	Inter- changeable	
"	iF 00:06:70	"	1S2473	"		
D117~120	iF 00:14:00	"	1SS82	"		
D121~124	iH 00:09:60	"	30DF1	"		
D125~129	iF 00:00:40	"	1S1555	"	Inter- changeable	
"	iF 00:06:70	"	1S2473	"		
D130	iF 00:16:20	"	1S2076A	"		
D131	iF 00:00:40	"	1S1555	"	Inter- changeable	
"	iF 00:06:70	"	1S2473	"		
D132	iF 00:14:70	Zener Diode	RD6.2EB2	ツェナーダイオード		
D133	iF 00:16:20	Diode	1S2076A	ダイオード		
D134	iF 00:14:70	Zener Diode	RD6.2EB2	ツェナーダイオード		
D135,136	iF 00:00:40	Diode	1S1555	ダイオード	Inter- changeable	
"	iF 00:06:70	"	1S2473	"		
D137,138	iF 00:14:70	Zener Diode	RD6.2EB2	ツェナーダイオード		
RY101 RY102	KC 00:08:10	Relay	D2-0 MSJ12	リレー		
	LA 00:21:10	Wrapping Terminal	P=5 2P (i Type)	i型ラッピング端子板		
	LA 00:21:20	"	P=5 3P (")	"		
	LA 00:20:30	"	P=5 4P (")	"		
	LA 00:35:10	Lock Terminal	4P	4Pワンロックターミナル		J,R,A,G,B
	LA 00:35:20	"	"	"		"
※	LA 00:35:50	"	"	"		U,C
※	LA 00:35:60	"	"	"		"

※ New Parts (新規部品)

Ref. No.	Part No.	Description	部 品 名	Remarks	Common Model	Markets		
	LB 40:05:70	2.5 Pitch Base Pin	TEB4P-SHF	2.5ピッチベースピン				
	CB 06:92:50	Binding Tie		インシュロックタイ				
	LA 00:41:20	Test Point Pin	1P	テストポイントピン				
	BB 06:52:50	Transistor Pusher		トランジスタプッシャー				
	BB 06:83:70	Ground Plate		アース金具	A-550			
	BB 06:62:90	Washer		アースワッシャー				
*	NA 07:76:00	Power Circuit Board		電 源 シ ー ト			J,R	
*	NA 07:76:10	"		"			U,C	
*	NA 07:76:20	"		"			A,G,B	
*	C701	FZ 00:27:80 Electrolytic Cap.	4700 μ F 16V	ケ ミ コ ン				
	C702	UW 93:71:00 "	10 μ F 16V	"				
	C703	UW 96:61:00 "	1 μ F 50V	"				
	C704	UW 96:71:00 "	10 μ F 50V	"				
*	C705,706	FZ 00:28:00 "	1000 μ F 100V	"				
	R701	HL 72:38:20 Metal Oxide Film Resistor	8.2 Ω 2P	酸 金 抵 抗				
	R702	HJ 35:51:00 Carbon Resistor	100 Ω RD25	カ ー ボ ン 抵 抗				
	R703~705	HJ 35:61:80 "	1.8k Ω "	"				
	R706	HJ 35:73:30 "	33k Ω "	"				
	R707	HJ 35:61:00 "	1k Ω "	"				
	TR701	iC 22:35:00 Transistor	2SC2235(O,Y)	ト ラ ン ジ ス タ				
	TR702	iC 19:83:00 "	2SC1983	"				
*	D701	iH 00:11:20 Diode Bridge	S2VB20	ダイオードブリッジ				
	D702	iH 00:02:80 Diode	1D2C1	ダ イ オ ー ド	Inter-changeable			
*	"	iH 00:11:80 "	S2VC10	"				
	D703	iF 00:02:00 Zener Diode	WZ-120	ツェナーダイオード				
	D704	iH 00:02:40 Diode	1S1885	ダ イ オ ー ド				
	D705,706	iH 00:07:10 "	W06C	"				
	F701,702	KB 00:04:20 Fuse	T2.5A 250V	ヒ ュ ー ズ			J,R	
	"	KB 00:07:50 "	T2.0A 250V	"			A,G,B	
	"	KB 00:11:10 "	2.5A 250V	"			U,C	
		LA 00:23:50 Wrapping Terminal	P=5 2P (L Type)	L型ラッピング端子板				
		LA 00:23:60 "	P=5 3P (")	"				
		LA 00:24:00 "	P=7.5 3P (")	"				
*		LA 00:26:20 "	P=5(ϕ) 3P (")	"				
*		LA 00:35:30 "	P=7.5 2P (")	"				
*		LA 00:35:40 "	P=7.5 3P (")	"				
		LB 20:18:80 Fuse Holder Pin	PC-FH1	ヒューズホルダーピン				
*		NA 07:76:30 Electrolytic Cap. Circuit Board		ケ ミ コ ン シ ー ト			J	
*		NA 07:76:40 "		"			R,A,G,B	
*		NA 07:76:50 "		"			U,C	
*	C801,802	FZ 00:29:90 Electrolytic Cap.	18000 μ F 50V	ケ ミ コ ン			J	
*	"	FZ 00:28:30 "	10000 μ F 50V	"			R,U,A,G,C,B	
*	C803,804	FZ 00:27:60 "	18000 μ F 80V	"				
	R801,802	HL 81:72:20 Metal Oxide Film Resistor	22k Ω 1P	酸 金 抵 抗				
	R803,804	HL 81:71:20 "	12k Ω 1P	"				
	R805,806	HJ 35:61:50 Carbon Resistor	1.5k Ω RD25	カ ー ボ ン 抵 抗				
	R807,808	HJ 35:58:20 "	820 Ω "	"				
*	D801	iH 00:11:60 Diode Bridge	4D4B41	ダイオードブリッジ				
	D802	iH 00:06:80 "	S5188	"				
		LA 00:23:80 Wrapping Terminal	P=5 2P (L Type)	L型ラッピング端子板				
*		LB 90:40:40 Connector Plug	4P (L Type)	コネクタプラグ				

* New Parts (新規部品)

Ref. No.	Part No.	Description	部 品 名	Remarks	Common Model	Markets
*	BA 08:11:00	Heat Sink,Diode		ダイオード放熱板		
	LA 00:24:30	Wrapping Terminal	P=5 2P (U Type)	U型ラッピング端子板		
	ED 33:01:20	Bind Head Screw	3x12 FCM3-Bℓ	バインド小ネジ		
*	NA 07:78:40	Pre Drive Circuit Board		ブリドライブシート		J
*	NA 07:78:50	"		"		R,A,G,B
*	NA 07:78:60	"		"		U,C
	C901,902	Ceramic Cap.	100pF 50V	セラコン		
	C903~906	Mica Cap.	22pF 500V	マイカコン		J
	"	FH 61:12:20	Ceramic Cap.	22pF 500V	セラコン	R,U,A,G,C,B
*	C907,908	Polypropylene Film Cap.	150pF 50V	ポリプロピレンフィルムコン		J
	"	FG 41:21:50	Ceramic Cap.	150pF 50V	セラコン	R,U,A,G,C,B
*	C909,910	Mylar Cap.	1μF	マイラーコン		J
*	"	UW 91:74:70	Electrolytic Cap.	47μF 6.3V	ケミコン	R,U,A,G,C,B
	C911,912	Mica Cap.	4pF 500V	マイカコン		J
	"	FH 61:04:00	Ceramic Cap.	4pF 500V	セラコン	R,U,A,G,C,B
	C913~916	Mica Cap.	22pF 500V	マイカコン		J
	"	FG 41:12:20	Ceramic Cap.	22pF 50V	セラコン	R,U,A,G,C,B
	C917~920	Mica Cap.	8pF 500V	マイカコン		J
	"	FH 61:08:00	Ceramic Cap.	8pF 500V	セラコン	R,U,A,G,C,B
	C921~924	Mylar Cap.	0.047μF 50V	マイラーコン		
	C925,926	Mica Cap.	68pF 500V	マイカコン		J
	"	FH 61:16:80	Ceramic Cap.	68pF 500V	セラコン	R,U,A,G,C,B
	C927~930	Electrolytic Cap.	22μF 100V	プラスチックケミコン		J
	"	UW 69:72:20	"	22μF 100V	ケミコン	R,U,A,G,C,B
	R901,902	Carbon Resistor	330kΩ RD25	カーボン抵抗		
	R903,904	HJ 35:58:20	"	820Ω "	"	
	R905,906	HJ 35:56:80	"	680Ω "	"	
	R907,908	HJ 35:42:20	"	22Ω "	"	
	R909,910	HJ 35:48:20	"	82Ω "	"	
	R911~914	HJ 35:63:30	"	3.3kΩ "	"	
	R915~918	HJ 35:64:70	"	4.7kΩ "	"	
	R919,920	HJ 35:83:30	"	330kΩ "	"	
	R921,922	HJ 35:43:90	"	39Ω "	"	
	R923~926	HJ 35:63:30	"	3.3kΩ "	"	
	R927~934	HJ 35:42:20	"	22Ω "	"	
	R935~938	HJ 35:62:20	"	2.2kΩ "	"	
	R939~942	HJ 35:53:30	"	330Ω "	"	
	R943~946	HU 07:51:80	Metal Film Resistor	18kΩ RE35	金属被膜抵抗	
	R947,948	HU 27:53:30	"	330Ω SHR	"	J
	"	HN 55:53:30	Carbon Resistor	330Ω R28USS	カーボン抵抗	R,U,A,G,C,B
	R951,952	HJ 35:81:50	"	150kΩ RD25	"	
	R953~956	HJ 35:64:70	"	4.7kΩ "	"	
	R957~960	HJ 35:61:00	"	1kΩ "	"	
	R961~964	HJ 35:46:80	"	68Ω "	"	
	R965~968	HV 35:52:20	Flame Proof Carbon Resistor	220Ω RDF25SF	不燃化カーボン抵抗	
*	VR901 VR902	HT 18:03:70	Metal Grazed Variable Resistor	B100Ω	メタルグレイズボリューム	
	TR901 TR902	iE 10:19:10	Dual FET	μPA68H (L,M)	デュアルFET	
	TR903 TR904	iC 27:05:00	Transistor	2SC2705(O,Y)	トランジスタ	
	TR905 TR906	iA 11:45:00	"	2SA1145(O,Y)	"	
	TR907 TR908	iA 07:77:30	"	2SA777(Q,R)	"	
	TR909 TR910	iC 15:09:30	"	2SC1509(Q,R)	"	
	TR911~ TR914	iC 17:75:10	"	2SC1775(D,E,F,G)	"	B-6

* New Parts (新規部品)

Ref. No.	Part No.	Description	部 品 名	Remarks	Common Model	Markets		
TR915 ~ TR918	iA 08:72:10	Transistor	2SA872(D,E,F,G)	ト ラ ン ジ ス タ	B-6			
TR919 TR920	iZ 00:01:20	Dual Transistor	μPA74V	デュアルトランジスタ				
TR921 TR922	iZ 00:01:30	"	μPA75V	"				
TR923 TR924	iA 06:73:10	Transistor	2SA673(C,D)	ト ラ ン ジ ス タ				
TR925 TR926	iA 09:14:50	"	2SA914(Q,R,S,T)	"				
TR927 TR928	iC 19:53:50	"	2SC1953(Q,R,S,T)	"				
TR929 TR930	iC 12:13:10	"	2SC1213A(C,D)	"				
D901~908	iF 00:14:70	Zener Diode	RD6.2EB2	ツェナーダイオード				
D909~912	iF 00:00:40	Diode	1S1555	ダ イ オ ー ド	Inter-changeable			
"	iF 00:06:70	"	1S2473	"				
D913~916	iF 00:08:30	Zener Diode	RD4.7E	ツェナーダイオード				
	LA 00:23:60	Wrapping Terminal	P=5 3P (L-Type)	L型ラッピング端子板				
	LA 00:23:80	"	P=5 3P (")	"				
	LB 30:07:30	2.5 Pitch Base Pin	TEB3P-SHF	2.5ピッチベースピン				
	NA 07:77:00	Control Circuit Board		制 御 シ ー ト		J		
	NA 07:77:10	"		"		R		
	NA 07:77:20	"		"		U,C		
	NA 07:77:30	"		"		A,G,B		
C601	UW 96:64:70	Electrolytic Cap.	4.7μF 50V	ケ ミ コ ン				
C602	UW 91:81:00	"	100μF 6.3V	"				
C603	FH 21:31:00	Ceramic Cap.	0.001μF 500V	セ ラ コ ン				
C604	FG 41:21:00	"	100pF 50V	"				
C605	UA 25:43:30	Mylar Cap.	0.033μF 50V	マ イ ラ ー コ ン				
C606	FA 45:54:70	"	0.47μF 50V	"				
C607	FQ 02:52:20	Oil Cap.	0.22μF 630V	オ イ ル コ ン		J		
"	FR 15:52:20	Metalized Paper Cap.	0.22μF 250V	M P コ ン		R		
"	FC 24:52:20	Metalized Mylar Cap.	0.22μF 125V	M M コ ン		U,C		
"	FR 15:54:70	Metalized Paper Cap.	0.47μF 250V	M P コ ン		A,G,B		
C608,609	Fi 34:33:30	Ceramic Cap.	0.0033μF 125V	セ ラ コ ン		J,U,C		
"	FR 16:36:80	Metalized Paper Cap.	0.0068μF 250V	M P コ ン		R,A,G,B		
C610	FR 16:36:80	"	0.0068μF 250V	"		R,A,G,B		
C611	FQ 02:51:00	Oil Cap.	0.1μF 630V	オ イ ル コ ン		J		
"	FQ 09:51:00	"	0.1μF 450V	"		R,A,G,B		
"	FC 24:51:00	Metalized Mylar Cap.	0.1μF 125V	M M コ ン		U,C		
L601	GD 90:04:20	Coil	150μH	雑 防 コ イ ル				
R601	HJ 35:73:90	Carbon Resistor	39kΩ RD25	カ ー ボ ン 抵 抗				
R602	HJ 35:58:20	"	820Ω "	"				
R603,604	HJ 35:73:90	"	39kΩ "	"				
R605	HJ 35:61:50	"	1.5kΩ "	"				
R606,607	HV 35:43:90	Flame Proof Carbon Resistor	39Ω RDF25SF	不 燃 化 カ ー ボ ン 抵 抗				
R608	HJ 35:63:90	Carbon Resistor	3.9kΩ RD25	カ ー ボ ン 抵 抗				
R609	HJ 35:71:50	"	15kΩ "	"				
R610	HJ 35:73:90	"	39kΩ "	"				
R611	HV 35:45:60	Flame Proof Carbon Resistor	56Ω RDF25SF	不 燃 化 カ ー ボ ン 抵 抗				
R612	HJ 35:56:80	Carbon Resistor	680Ω RD25	カ ー ボ ン 抵 抗				
R613	HJ 35:81:00	"	100kΩ "	"				
R614	HJ 35:82:20	"	220kΩ "	"				
R615	HJ 35:71:00	"	10kΩ "	"				
R616	HJ 35:75:60	"	56kΩ "	"				
R617	HJ 35:81:50	"	150kΩ "	"		J		
"	HL 72:81:00	Metal Oxide Film Resistor	100kΩ 2P	酸 金 抵 抗		R,U,A,G,C,B		
R621	HL 72:71:00	"	10kΩ 2P	"		J		

✦ New Parts (新規部品)

Ref. No.	Part No.	Description	部 品 名	Remarks	Common Model	Markets
R621	HL 72 73:90	Metal Oxide Film Resistor	39kΩ 2P	酸 金 抵 抗		R,A,G,B
"	HL 72 71:20	"	12kΩ 2P	"		U,C
R622	HL 72 73:90	"	39kΩ 2P	"		R,A,G,B
R623	HV 35 61:00	Flame Proof Carbon Resistor	1kΩ RDF25SF	不 燃 化 カ ー ボ ン 抵 抗		
R624	HJ 35 84:70	Carbon Resistor	470kΩ RD25	カ ー ボ ン 抵 抗		
R625	HJ 35 71:50	"	15kΩ "	"		
R626	HJ 35 81:50	"	150kΩ "	"		J
"	HJ 35 81:80	"	180kΩ "	"		A,G,B
"	HJ 35 81:20	"	120kΩ "	"		R,U,C
R627	HJ 35 71:00	"	10kΩ "	"		J
"	HJ 35 75:60	"	56kΩ "	"		R,U,C
"	HJ 35 81:80	"	180kΩ "	"		A,G,B
R629	HV 35 41:50	Flame Proof Carbon Resistor	15Ω RDF25SF	不 燃 化 カ ー ボ ン 抵 抗		
R630,631	HJ 35 54:70	Carbon Resistor	470Ω RD25	カ ー ボ ン 抵 抗		
* R632	HL 72 53:90	Metal Oxide Film Resistor	390Ω 2P	酸 金 抵 抗		
R633	HL 71 42:70	"	27Ω 1P	"		J,U,C
"	HL 71 44:70	"	47Ω 1P	"		R,A,G,B
VR601	HT 18 02:10	Semi Variable Resistor	B5kΩ	半 固 定 抵 抗		
* VR602	HY 00 10:30	Metal Grazed Variable Resistor	B5kΩ	メタルグレイズボリューム		
TR601	iA 09 49:00	Transistor	2SA949(O,Y)	ト ラ ン ジ ス タ		
TR602 TR603	iA 09 70:00	"	2SA970(GR,BL)	"		
TR604	iC 18 15:70	"	2SC1815(O,Y)	"		
TR605	iC 22 40:00	"	2SC2240 (GR,BL)	"		
TR606	iK 00 03:00	Photo Coupler	TLP508 (V)	フ ォ ト カ ブ ラ		
D601,602	iF 00 14:70	Zener Diode	RD6.2EB2	ツェナーダイオード		
D603~605	iF 00 00:40	Diode	1S1555	ダ イ オ ー ド	Inter- changeable	
"	iF 00 06:70	"	1S2473	"		
D606,607	iF 00 19:40	Zener Diode	HZ-24	ツェナーダイオード		
D608	iH 00 08:80	Diode Bridge	S1WB	ダイオードブリッジ		
D609~610	iF 00 14:00	Diode	1SS82	ダ イ オ ー ド		J
"	iH 00 00:60	"	10D-4	"		R,U,A,G,C,B
R611,612	iF 00 14:00	"	1SS82	"		
IC601	iG 04 08:00	IC	iG04080	ト リ ガ ー I C		
* SCR601	iH 00 11:50	Thyristor	0.3A SFOR3G42	サ イ リ ス タ		
SCR602	iH 00 09:00	Triac	0.5A SMOR5G42	ト ラ イ ア ッ ク		
SCR603	iH 00 10:50	"	16A AC16DGM-L	"		
F601	KB 00 12:70	Fuse	T15A 125V	ヒ ュ ー ズ		J
"	KB 00 13:80	"	15A 250V	"		R,U,C
"	KB 00 22:40	"	F6.3A 250V	"		A,G,B
	LA 00 23:70	Wrapping Terminal	P=5 4P (L Type)	L型ラッピング端子板		
	LA 00 24:10	"	P=10 2P(")	"		
	LA 00 24:20	"	P=10 3P(")	"		
	LB 20 09:00	Fuse Holder Pin		ヒューズホルダーピン		
* BA 08 11:70	Heat Sink			放 熱 板		J,R,U,C
BA 07 95:30	"			"		A,G,B
BB 06 62:90	Washer			アースワッシャ		
iL 00 04:00	Isolation Bush			絶 縁 ブ ッ シ ュ		J,R,U,C
CB 07 28:80	"			"		A,G,B
* iL 00 06:60	Triac Plate			トライアック押え金具		J,R,U,C
CB 60 38:40	Coil Cap.			コイルキャップ		
CB 60 40:80	Coil Base			コイルベース		
iL 00 02:70	Mica Base	AC-229		マイカベース		
EA 03 01:00	Pan Head Screw	M3x10 ZMC2-Y		ナベ小ネジ		

* New Parts (新規部品)

